

Research Article

Towards Inclusive Transportation: Smart Steps for Elderly Commuters in the Public Transport Buses

T. Ravi

G. Babu Rao*

B. Praveen Kumar

M. Wilson Kumar

Division of Mechanical Engineering,
Karunya Institute of Technology and
Sciences (Deemed to be University),
Coimbatore – 641 114, India

Received 27 February 2024

Revised 27 June 2024

Accepted 2 July 2024

Abstract:

This paper addresses a significant issue prevalent among elderly populations worldwide: the fundamental accessibility of public transportation. This accessibility remains a cause for concern since many countries primarily procure buses designed to serve the younger demographic, with limited consideration for the elderly. One prominent challenge arises from the elevated floor height of these buses, resulting in high steps and multiple stairs, rendering boarding nearly impossible for elderly and disabled individuals. In such cases, boarding often necessitates assistance from another person. These factors not only impede the personal and social development of elderly individuals but also restrict their participation in society. To tackle this issue, the authors have undertaken the task of designing and developing a functional prototype that can be retrofitted onto buses to ensure safe travel for the elderly. The system's initial creation involved the use of 3D modelling software, followed by a comprehensive structural stability analysis conducted through the ANSYS Workbench. Subsequently, the authors fabricated the physical prototype. It is worth noting that the system operates efficiently, reducing boarding and deboarding times to about one minute each during the laboratory trials.

Keywords: Dynamic steps, Public buses, Elderly people, Transient analysis

1. Introduction

The global population is experiencing a significant demographic shift, with a growing proportion of older adults. This is due to factors such as improved healthcare, sanitation, and medicine, which have led to increased life expectancy and decreased mortality rates [1, 2]. The United Nations projects that the population over the age of 60 will increase from 800 million today to over 2 billion in 2050, representing 22% of the world population [3]. This trend is also seen in high-income countries, with many having more people over the age of 65 than under the age of 15 [3]. By 2050, it is projected that there will be more people over the age of 65 than under the age of 15 for the first time in human history [2]. This ageing population presents significant challenges for healthcare systems worldwide, as there will be greater demand for care for non-communicable diseases and a need to develop appropriate care delivery methods for the elderly [2]. The cost of providing these services will strain the infrastructures of both developing and developed countries [2]. Among them, Elderly and disabled individuals face significant challenges in accessing public transportation, particularly buses, due to elevated floor heights and multiple steps [4]. These physical barriers can make it difficult for individuals with mobility impairments to board and disembark from buses, limiting their ability to use public transportation [5].

* Corresponding author: G. Babu Rao
E-mail address: gadudasubaburao4974@gmail.com



Specific challenges include difficulties with transferring in and out of vehicles, navigating steps and stairs, limited access to accessible vehicles, wheelchair access and storage issues, and a lack of accessible spaces [6]. These challenges are further exacerbated for individuals living in rural areas where access to public transit and taxi/ride-share services is limited. Financial limitations, advanced planning, and waiting times also pose barriers to accessing transportation for elderly and disabled individuals [6]. The lack of accessibility in public transportation has significant impacts on the personal and social development of elderly individuals. It can lead to social isolation and reduced independence, as individuals may be unable to participate in social activities, access healthcare services, or engage in employment or educational opportunities [5]. This can have negative effects on mental and physical well-being, as well as overall quality of life [7]. Extensive research and development efforts [8-15] have been dedicated to aiding elderly and individuals with limited mobility in the boarding and deboarding process of buses. However, developed nations have implemented and partially addressing the issues, but many developing countries [16-21] still struggle to provide the necessary facilities and mechanisms to facilitate smooth boarding and deboarding for elderly passengers. Our exploration of the increasing elderly population worldwide and the associated challenges has revealed pressing issues that demand our attention. Healthcare systems face the daunting task of adapting to the needs of a growing aging demographic, with significant financial implications for both developed and developing nations. Concurrently, the elderly and disabled encounter formidable barriers when it comes to using public transportation, affecting their mobility, social engagement, and overall well-being. Here, the authors of this paper have embarked on a pioneering journey [22], driven by the vision of creating an innovative solution. The endeavour involves the development of a specialized prototype designed to enhance the accessibility of buses, particularly for elderly passengers. This promising initiative has the potential to significantly improve the lives of older individuals by making public transportation more accommodating. Further details on this innovative solution are discussed in the subsequent sections of this article.

1.1 Infrastructure Developments – Based on Published Work

The infrastructure improvements made for the community of the elderly and disabled to facilitate ease of embarking and disembarking in public transportation vehicles are discussed in this section. This section explores infrastructure developments to the current period based on conceptual/experimental work published in journals/patents/books, etc. Cripe and Caylor [23] designed and patented a staircase mechanism for a passenger vehicle. The system is mounted with arm and link mechanism to provide the required motion of the steps from ground level to the platform as shown in Fig. 1 [23]. Dickhart and Marvin [24] patented a lifting device meant for boarding/deboarding in the railway coaches disabled wheelchair users. The system used a motor-chain driven mechanism to lift the platform over the initial step to final steps keeping it in a horizontal position as shown in Fig. 2 [24]. Hagen [25] designed a laterally extending staircase assembly for passengers to avoid injuries because of the gap between the vehicle and edge of the boarding platform. The assembly consisted of a linkage mechanism, ensures that there exist no gap during boarding as shown in Fig. 3 [25]. Uras and Aktan [8] developed a prototype for wheelchair lift which can be installed in transit buses. This is capable of lifting a wheelchair user or elderly person from the ground to the bus floor level using two hydraulic actuators with a load capability of 3300N [8]. Demski et al. [26] designed and installed an automatic extending and retracting step-down system that was synced with the motion of the vehicle door. The system, here is powered by a linear hydraulic actuator for actuating the steps to both downward and upward direction, as depicted in Fig. 4 [26]. Matre [27] patented a dual stairway and lifting system designed specifically for those with and without disabilities who have difficulties climbing steps. As shown in Fig. 5, this link-based lift mechanism ensures that the platform is lifted or lowered while maintaining all of the steps horizontally [27]. Stefan [28] proposed a conceptual lifting mechanism for a campus bus that is designed primarily for accessible by handicapped people. The mechanism is modeled in ADAMS software with a Scissors linkage mechanism that stretches the platform in and out during boarding and deboarding. In addition, the research includes a survey to identify customer needs, based on which a conceptual design was created and evaluated using static and dynamic computations [28].

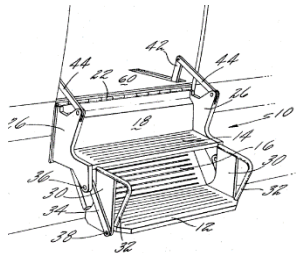

Fig. 1. Folding staircase [23]

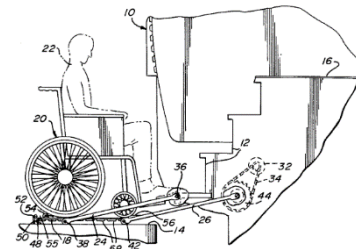

Fig. 2. Railway car trap door lift [24]

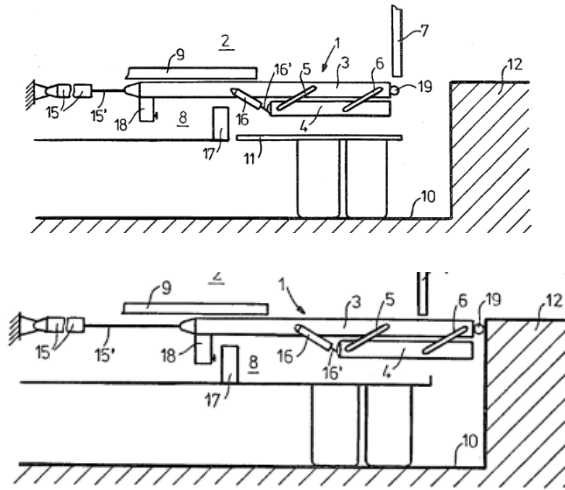

Fig. 3. Folding system for Vehicles [25]

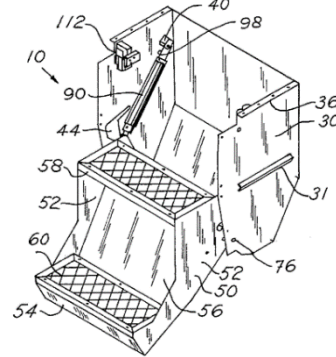

Fig. 4. Folding system for Vehicles [26]

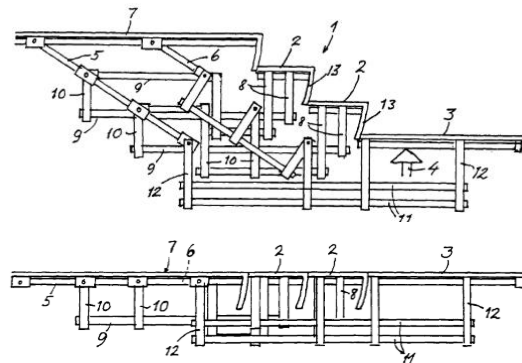

Fig. 5. Combined stairs and lifts [27]

Pourhassana et al. [10] designed and analyzed a novel mechanism for wheelchair bond/disabled people to ease embarking and disembarking in public transportation vehicles. This mechanism mounted on two rails with one being fixed and other being movable. The mechanism allows for two linear movements and one rotary movement with a hydraulic power pack. The system is validated using manual design calculations and analysis using ADAMS software. Lee et al. [29], performed structural analysis on the elevator design used for lifting wheelchair bond passengers from ground level to the bus floor level for use in Korean express buses. They have taken FMVSS Part 571.403 with standard and guaranteed load conditions were considered for performing the structural analysis and ensures that the design withstand the guaranteed loads [29]. Rahman et al. [30] designed and analyzed a wheelchair lifting system for use in high floor buses in Bangladesh. The system consists of one vertical and one horizontal movement of steps which are functioned with the help of a linear actuator, two rack and pinion mechanism simultaneously. The feasibility of the system has been tested by simulation analysis [30]. Paul et al. [31] published a

paper about the conceptual design and analysis of the stair lift for the elderly and physically disabled. In the proposed design, the first step is connected to a linear electrical actuator that, when engaged, lifts the user up to the third step from the ground (bus floor). Spikes under the first and second steps ensure that all three steps will be parallel as they approach the height of the bus floor, allowing a person to embark securely [31]. Ahmed and Islam [32] developed a plywood wheelchair ramp prototype for use in Bangladeshi public buses and used Solidworks simulation to undertake a design study based on ADA rules. The prototype's practical applicability was tested, and satisfactory outcomes were achieved for adapting the prototype to practical implementation. However, suggestions were made to find lighter, wear-resistant materials for real practice in future [32]. Seino et al. [33] developed a novel lifting system for wheelchair bound passengers with a mechanism that can be fitted in both steps and stairs and occupies less space. The system also has one degree of freedom. In order to assess the performance of this system, equal and uneven loads were kept on the platform during the experimental validations [33]. Sankarlal et al. [14] designed a ramp-based wheelchair raising platform for usage in India's high-floor government buses. The design is based on the Americans with Disabilities Act (Americans with Disabilities act). For lifting and lowering the ramp, the system employs a chain and sprocket mechanism. In addition, a sandwich type material is used for the ramp, with aluminium and mild steel at the top and bottom of the ramp and wood in the middle. The design is evaluated using explicit analysis to ensure structural integrity [14]. Peravali et al. [34] deigned a conceptual model of automated dynamic steps for people with walking difficulty to travel safely in public vehicles. The system consists of various sensors to automate the steps position and actuation by manual push button activation. The first step is connected to the lead screw system which will be raised to the bus floor level and lowered to the ground level based on the commands received by the microcontroller [34].

1.2 Infrastructure Developments – Based on Market Available Products

This section discusses on the market available products that are installed in the public transport vehicle to ease boarding/deboarding for people with/without disabilities.

Government of India is urging the states to purchase buses that are elderly and disability friendly in light of the challenges encountered by the country's elderly and disabled population. The state government of Tamil Nadu, India, has received orders from the Madras High Court stating that they are no longer permitted to purchase buses that are not accessible to individuals with/without disabilities. It was further clarified that purchasing a non-friendly accessible bus will result in infringement of court statutes and the Rights of Persons with Disabilities Act [35]. According to a press release on 27th July 2022 by Indian Ministry of Road Transport and Highways, about 51,043 of the 1,45,747 buses operating by various Indian states have accessibility for elderly and disabled passengers to board and deboard [36]. Out of the accessible bus numbers, 42,348 (29.05%) are partially accessible and 8,695 (5.96%) are fully accessible [37], which is extremely low given India's ageing population in the coming years.

Despite the fact that the government is undertaking a number of initiatives to enhance the lives of the elderly and disabled populations, the reality of access to these buses remains unknown. This section reviews the infrastructure implementations made to India's public buses to ease boarding and deboarding in some of the states.

Brihanmumbai Electric Supply and Transport (BEST) installed a new ramp-based mechanical lift mechanism on a 25-seater Tata Ultra Urban AC electric bus. According to Tata Motor authorities, the lift operates on a linkage system that extends the ramp on/off the road with the help of push button at drivers desk and takes roughly 30 seconds to make wheelchair bond passengers with a maximum weight of 170Kg board the bus as shown in Fig. 6 [38]. Bangalore Metropolitan Transport Corporation (BMTC) has been running low floor bus for the benefitting the elderly community but the same has been a barrier for the wheelchair bond passengers. Keeping this in mind, now they are going to deploy buses equipped with the ramp-based wheelchair lifting mechanism for making commuting easier for differently abled people. The facility can be operated by the bus crew with a push button remote as shown in Fig. 7 [39].



Fig. 6. Ramp based Wheelchair lift installed in Electric Bus in Mumbai [38].



Fig. 7. Ramp based wheelchair facility in Bangalore Electric bus [39].



Fig. 8. Ramp based wheelchair facility in Bihar and Delhi CNG Bus [40].



Fig. 9. wheelchair lift prototype in Tamil Nadu [41]

The governments of Bihar and Delhi have also introduced new wheelchair-accessible buses. The implemented mechanism differs from the previous design. As depicted in Fig. 8, the mechanism allows the ramps to glide horizontally and lowers down to allow people to board [40]. After the disabled passenger has boarded the bus, the system will accommodate under the stairs area and allow other passengers to board and deboard [40, 42, 43].

The Government of Tamil Nadu made transportation in ordinary buses free of charge for the women and disabled community in order to support the elderly/disabled and bring equality in the society. However, this move did not work well because only one bus out of 3300 MTC (Metropolitan Transport Corporation) buses were introduced with a ramp-based wheelchair lifting system as shown in Fig. 9 [41]. A disabled person has been asked to take part in the demonstration and evaluation of this accessible MTC bus lifting mechanism. Unfortunately, she fell backward off the ramp as she attempted to board the vehicle, injuring the back of her head on the concrete floor. As a result of the panic in the crowd, the implementation was temporarily suspended [41].

The Indian government is attempting to introduce more accessible vehicles in the future but given the condition of the roads and the cost for low floor buses, it would be best to modify the buses that currently travel to rural areas of Indian states rather than purchasing new ones that would cost crores of rupees. This would benefit both the elderly and disabled population of major cities as well as those who live in rural areas. However, the mechanisms involved in the present infrastructure fall short of meeting the demands of the people since the roads are limited and the space necessary for extending the platform is significantly greater in heavy traffic locations in India. As a result, there is a significant need to create innovative design mechanisms that can easily lift the elderly/disabled person while taking into account India's road conditions and busy traffic.

Also, in China some of the buses are installed with lifting devices to facilitate boarding and deboarding for individuals with and without disabilities outside of India. Because the mechanism for the majority of the designs remains the same, a few designs have been covered here.



Fig. 10. Semi-automatic Wheelchair lifting system for a bus in china [44].



Fig. 11. Fully Automatic Wheelchair lifting system for a bus in china [45].

A Chinese company which is a professional manufacturer of mobility solutions have developed variety of lifting devices to help the elderly and disabled community to board and deboard buses. The STEP -B-1200 device depicted in Fig. 10 is a semi-automatic system that employs a hydraulic pack to elevate the platform to a maximum height of 1150 mm and with a motor power of 800W to lift a maximum load of 300kg [44]. Some of the characteristics of this system are an anti-skid platform, warning sounds, railings, and manual operation upon failure [44]. This company also manufactured a lifting system named STEP-A-1200 as shown in Fig. 11 which is fully automatic device that can lift the platform to maximum height of 1150 – 1600mm [45].

According to the thorough review that was undertaken, it is apparent that there is a significant need for the development of new technology that will make it easier for elderly and disabled persons to travel in public transportation vehicles safely and comfortably. In India, older persons with less physical endurance find it more difficult to board and exit buses on their own. They regularly need assistance, and while doing so at bus stops without ramps or elevators, they commonly stumble or fall. Also, elderly persons with lower extremities also require assistance while boarding or disembarking from buses that do not have an automatic boarding system or lift that is operable during busy periods such as evenings and weekends. Therefore, there is high need of technology advancements that will make the possibility for making it easier for older individuals with lower extremities to board and deboard buses. It would be best to install lifting systems in buses considering the issues that the current infrastructure lacks in and the road conditions, traffic and limitation of space etc., so that the elderly/disabled people will be seen in actively participating equally in the society.

2. Experimental Setup

This section delves into the various stages involving the design to testing phase. Initially, in the development of the dynamic bus steps, precise measurements of a high-floor bus step were essential, given that all our university buses are high floor only therefore, measurements were taken from one of these buses, and subsequently, SolidWorks 2022 modelling software was used to model and assemble the system in a virtual environment, as depicted in the Fig. 12.

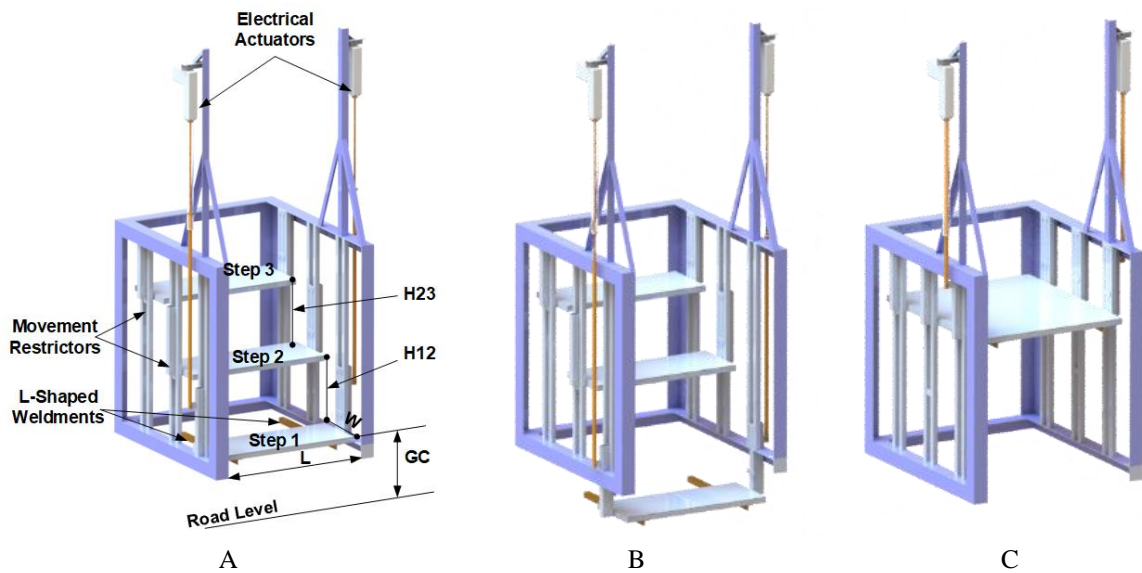

Fig. 12. Complete assembly modelled in SolidWorks 2022 virtual environment.

Based on the measured dimensions as shown in the Table 1, the mechanism is designed efficiently utilizing existing space, replacing conventional steps with dynamic ones. This feature eliminates the need for additional installation space, facilitating easy boarding and deboarding for ordinary individuals when not in use.

Table 1: Measured dimensions of stairs of the university bus.

S. No.	Description	Code	Measured Values (mm)
1	Length of the steps	L	670
2	Width of the steps	W	260
4	Height from the Road Level to first step	GC	600
5	Height between first step and second step	H12	200
6	Height between second step and third step	H23	300

The mechanism comprises three steps, denoted as S1, S2, and S3. Step 1 (S1) functions as the primary load bearer and is connected to two parallel electric actuators, each with a load-bearing capacity of 2000N, as shown in Fig. 12(A). Additionally, two L-shaped weldments are attached underneath S1 to assist in raising Step 2 (S2) to the level of Step 3 (S3). In practical scenario, when retrofitted to a bus, the existing steps are removed, and this mechanism is welded in place. The setup enables Step 1 to come down to ground level (road level), allowing an individual to board the bus by stepping onto it, as shown in Fig. 12(B). The mechanism then elevates the person to the level of Step 3, as depicted in Fig. 12(C). This design ensures a seamless boarding and deboarding experience for elderly individuals, providing them with safe and efficient access to the bus.

3. Transient Structural Analysis of Dynamic Steps

The structural stability of the design was assessed using the Ansys Workbench tool. The analysis commenced by converting the assembled model into a graphical exchange format (IGES) for importing into the Workbench environment. Materials were then assigned to all parts of the assembly, and the details of these assignments are provided in Table 2.

Table 2: Details of the materials assigned in workbench analysis.

S. No.	Properties	Lead Screw (Structural Steel)	Nut (Bronze)	Other Parts (Aluminium)
1.	Modulus of Elasticity	206000 MPa	117000 MPa	71000 MPa
2.	Poisson's Ratio	0.33	0.34	0.33
3.	Tensile Yield strength	250 MPa	165 MPa	280 MPa

To ensure the structural integrity and performance of the dynamic steps, a transient structural analysis was conducted. Initially, meshing was done with default settings (fine), and then boundary conditions were applied, as shown in Fig. 13(A) and Fig. 13(B). This analysis involved applying a sample load of 2000N on the first step for the initial four seconds, followed by three seconds on the second step, and the final three seconds on the third step.

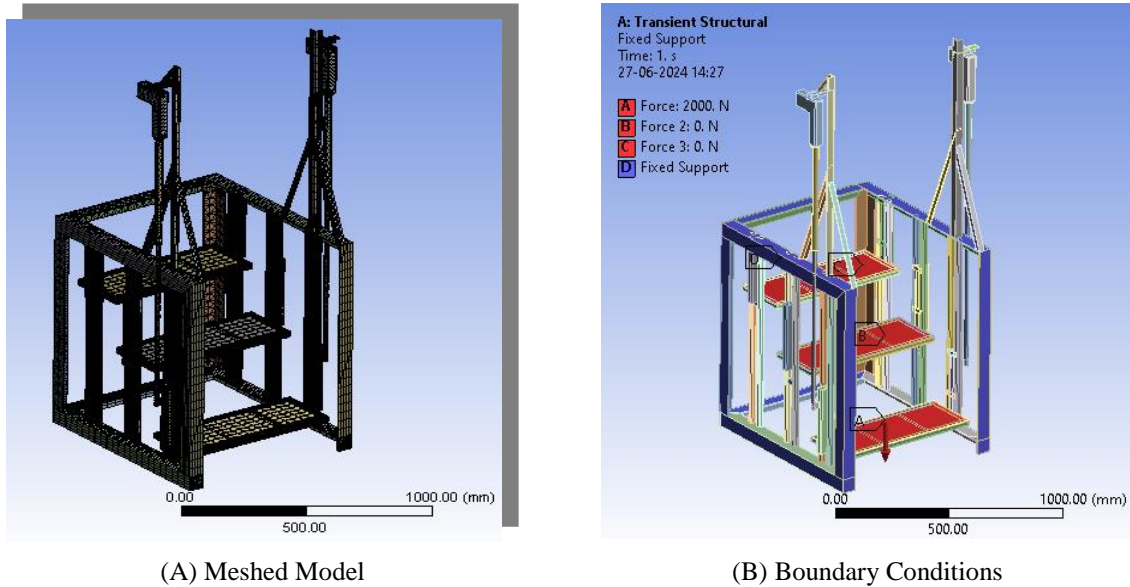

Fig. 13. Meshed Model and Applied Boundary Conditions

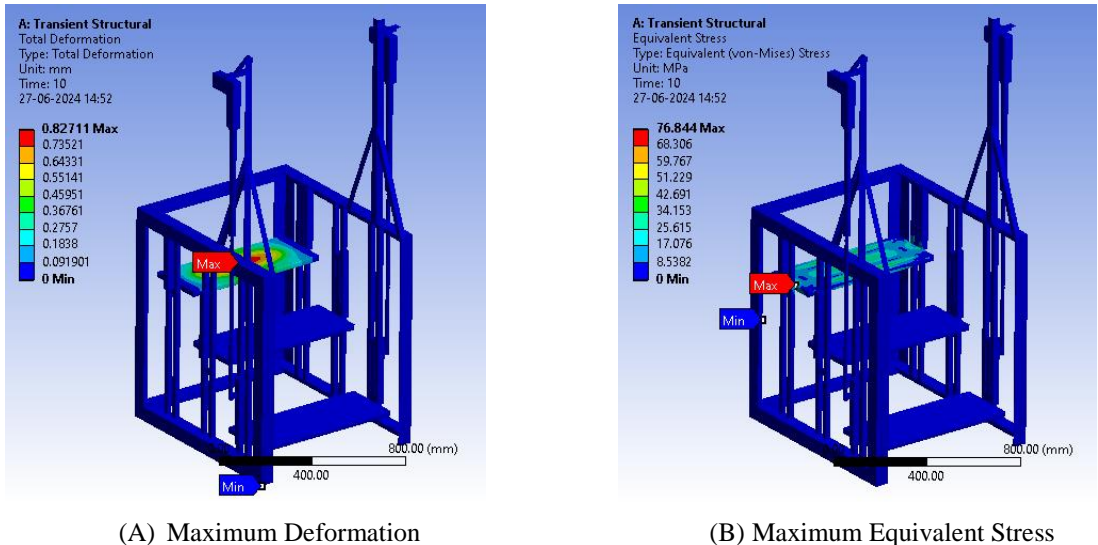

Fig. 14. Total deformation and Equivalent Stress of Steps 1,2 and 3 for a period of 10 seconds

The transient structural analysis spanned a ten-second period with a 0.5-second timestep. During this analysis, a sample load of 2000N was applied to the first step for the initial four seconds, followed by a load on the second step for the next three seconds, and finally on the third step for the remaining three seconds. The study of total deformations revealed values of 0.085204 mm, 0.084576 mm, and 0.082713 mm for the first, second, and third steps, respectively, as illustrated in Fig. 14(A). These negligible deformation values indicate that the design is structurally sound and capable of maintaining its integrity under operational loads. Additionally, equivalent stress values were calculated at various time intervals during the analysis. At 1, 5, and 9 seconds, the equivalent stress values were

76.673 MPa, 72.755 MPa, and 76.845 MPa, respectively, as depicted in Table 3. These values are well within acceptable limits, demonstrating that the dynamic step mechanism can withstand the operational loads without compromising safety or functionality.

Table 3: Transient analysis results of dynamic steps in Ansys workbench

Time (Sec)	Total deformation (mm)	Equivalent stress (MPa)	Maximum shear stress (MPa)	Factor of safety (FoS)	Tensile yield strength (MPa)		
					Steel structural	Bronze	Aluminium
1	0.85204	76.673	42.12	3.2606			
2	0.85205	76.674	42.12	3.2606			
3	0.85203	76.672	42.119	3.2606			
4	0.84575	72.754	39.457	3.4362			
5	0.84576	72.755	39.458	3.4362			
6	0.84574	72.754	39.457	3.4363	250	165	280
7	0.84576	72.755	39.458	3.4362			
8	0.82712	76.844	41.044	3.2533			
9	0.82713	76.845	41.045	3.2533			
10	0.85204	76.673	42.12	3.2606			

The above table details the values of total deformation and equivalent stresses for each step. The maximum equivalent stress value observed was 76.673 MPa, which is significantly lower than the yield strength of the material used in the construction of the steps. According to the Automotive Industry Standards (AIS 153), clause 3.11.3.1.2 on page 51, the lift should be able to carry a load of 300 kg. Assuming an average person's weight to be 100 kg, this gives a factor of safety of 3. Since the values given in Table 3 significantly fall below the material's yield strength of 250MPa, providing assurance that the design is secure and capable of withstanding loads without experiencing significant deformation or failure. This confirmation validates the feasibility of manufacturing the actual prototype in accordance with the modelled assembly and analysis,



(A) JIECANG Remote and Controller



(B) JIECANG Electrical Actuator

Fig. 15. Specifications of the remote, controller and electrical actuator

Following the confirmation of structural stability and functionality through the Workbench analysis, the full-scale prototype was fabricated and tested. The mechanism is operated using a remote control handled by the operator. The remote controller consists of an upward arrow and a downward arrow and a controller, as shown in Fig. 15(A).

When an elderly individual wishes to board the bus, they stand on Step 1 as shown in Fig. 16(A). The operator presses the button with the upward arrow on the remote control as shown in Fig. 15(A). This action initiates two electrical actuators, each with a load-bearing capacity of 2000N and a lead screw mechanism, which start the clockwise rotation of the motors, gradually lifting Step 1. As Step 1 rises to the level of Step 2, the elderly individual moves onto Step

2 as shown in Fig. 16(B). The L-shaped weldments underneath Step 1 provide support and assist in lifting Step 2, as illustrated in Fig. 12(A). When Step 1 and Step 2 become parallel again, the elderly individual moves onto Step 3. Finally, when Step 1 reaches the level of Step 3, all steps align in parallel, as shown in Fig. 16(C), facilitating easy boarding for elderly individuals. The average speed for the boarding process is takes around 52 seconds.

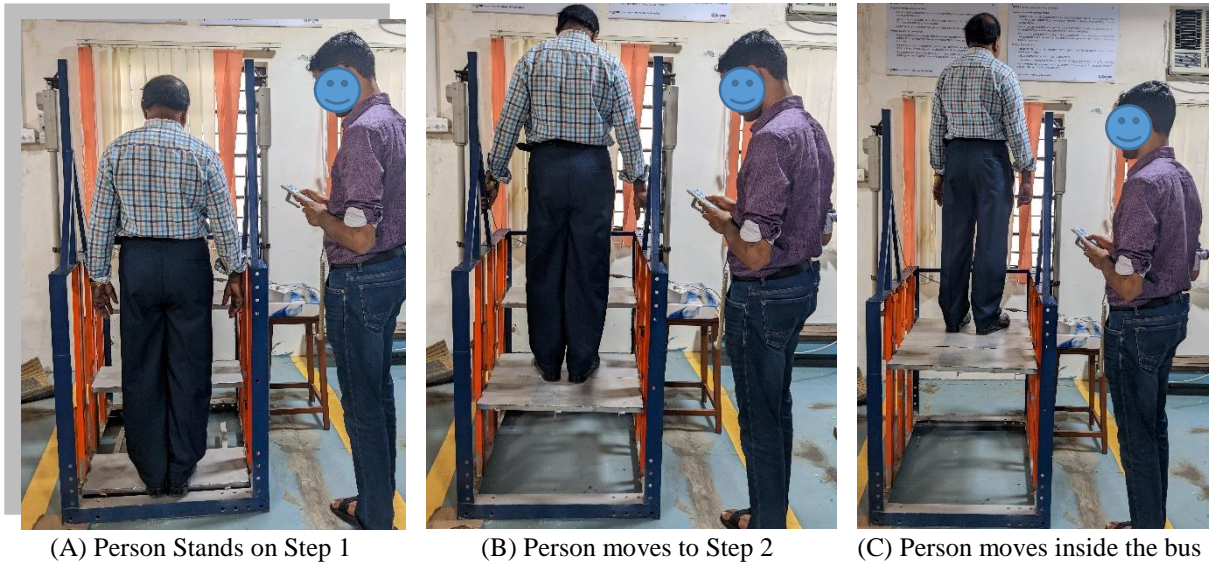

Fig. 16. Laboratory Trials of dynamic steps when boarding

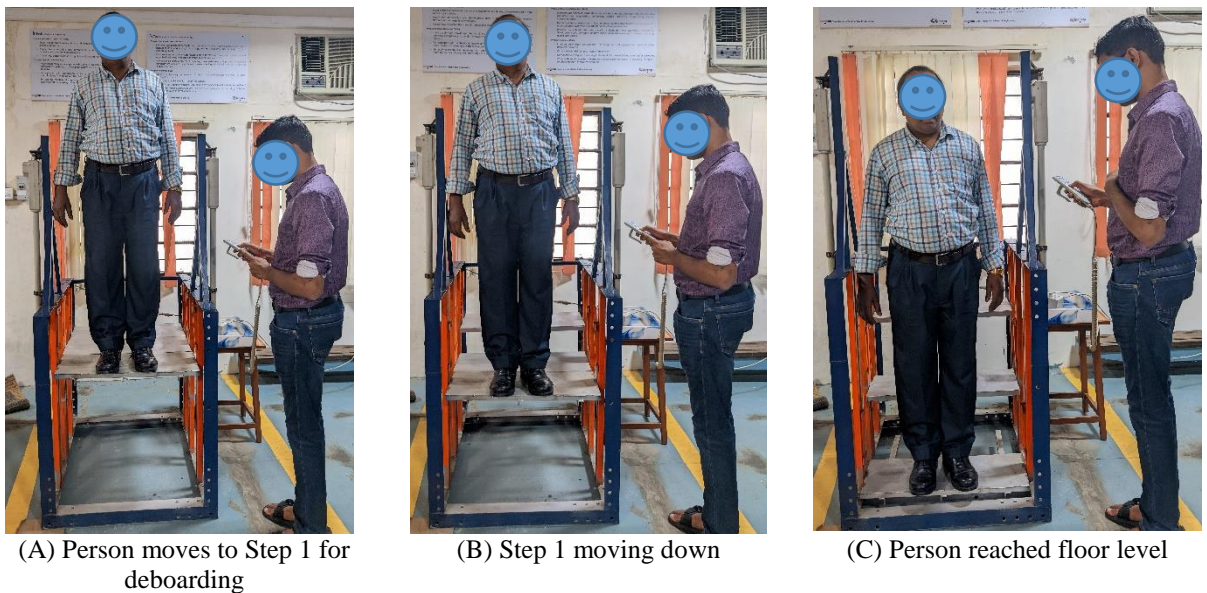

Fig. 17. Laboratory Trials of dynamic steps when deboarding

When the elderly individual wishes to deboard the bus, they first move to stand on Step 1 as shown in Fig. 17(A). The operator then presses the button with the downward arrow on the remote control as shown in Fig. 15(A). This action reverses the rotation of the motors to counterclockwise, causing the actuators to gradually lower Step 1. As Step 1 descends, the L-shaped weldments guide Step 2 downwards, ensuring it remains supported and stable. When Step 1 reaches its original lower position, all steps return to their initial configuration, as depicted in Fig. 15(C), allowing the elderly individual to safely step off the bus. The average speed for the deboarding process is 34 seconds and the total time for the complete boarding and deboarding process takes around 87 seconds.

4. Results and Discussion

This paper details an effort to design and develop an adaptable mechanism intended for retrofitting onto public transport buses with elevated floors. The primary objective is to facilitate easy access for the elderly and individuals with limited mobility, enabling them to board and deboard buses independently, without requiring assistance. The device has been carefully designed and subjected to analysis using Ansys Workbench 2015. Results indicate that the deformation values and equivalent stress values remain within safe limits under an applied load of 2000N. Deformation is negligible, and stress values are well below the materials' yield strength. A prototype has been fabricated and tested in the laboratory, depicted in Fig. 16 and Fig. 17, revealing positive responses from participants as shown in Table 4, affirming its viability for potential implementation.

Table 4: Smart steps participant response data based on age groups.

S. No.	Age group (Years)	35 to 45	46 to 50	50 to 55	55 to 60
1	Participant distribution (%)	30%	20%	20%	30%
2	Average weight (kg)	68	73	72	83
3	Average boarding time (seconds)	50	53	52	54
4	Average deboarding time (seconds)	33	35	35	36
5	Difficulty in boarding bus steps (%)	83%	100%	100%	100%
6	People with lower extremity pathology (%)	33%	75%	100%	67%
7	People recommended for smart step implementation (%)	100%	75%	100%	100%

Data from participants aged 35 to 60 years strongly supports the need for the smart step mechanism in buses. Many people have trouble getting on and off buses the existing bus due to height of the first step from the road level. The participants included 30% from the 35-45 and 55-60 age groups, 20% from the 46-50 age group, and 20% from the 50-55 age group. The average weight of participants ranged from 68 kg to 83 kg, showing that the smart step needs to be strong enough to support different weights. The average time to board the bus was between 50 to 54 seconds, and the time to get off was between 33 to 36 seconds. These long times highlight the inefficiency of current bus steps and the potential for the smart step to improve the process in future to bring it below 60 seconds. Most participants, especially those aged 46-60, reported difficulty with current bus steps, and many have lower extremity issues, especially those aged 50-55. The recommendation for the smart step was very positive, with 100% support from those aged 35-45, 50-55, and 55-60, and 75% from those aged 46-50. This strong support shows the need for a better boarding and deboarding solution. The smart step mechanism, designed to be retrofitted to buses, meets these needs by providing a safer, more accessible, and efficient way for elderly passengers to get on and off. With a design that can handle an average boarding time of 45 seconds and deboarding time of 30 seconds, the smart step mechanism promises to greatly improve the public transportation experience for older adults, ensuring their safety and comfort.

5. Conclusion

It can be concluded that, based on the laboratory trials and feedback from participants, it is evident that certain improvements are essential for the smart step mechanism. First and foremost, addressing the gap between steps is crucial to prevent potential injuries that may occur if unnoticed during dynamic movements. This can be achieved by incorporating a retractable plate that covers the gap and retracts when the steps align parallel. Additionally, incorporating different speed modes would allow users to customize boarding and deboarding times according to their requirements. Furthermore, it is essential to develop a mechanism that facilitates access for wheelchair-bound users. To minimize costs and operational errors associated with synchronizing motors, a proposed solution involves implementing a single motor system to drive the entire mechanism. Considering these findings, developing a modified prototype is recommended to further enhance the device. This improvement aims to empower individuals with mobility challenges, enabling them to confidently board and deboard buses independently, without requiring assistance from others.

Acknowledgement

The authors are very grateful to the Department of Science and Technology DST- SEED Division, Government of India for providing the financial assistance with Sanction No: SEED/TIDE/2019/770/G, under the scheme 1819-Innovation, Technology Development and Deployment.

References

- [1] Kanasi E, Ayilavarapu S, Jones J. The aging population: demographics and the biology of aging. *Periodontol* 2000. 2016;72(1):13-18.
- [2] Lunenfeld B. An Aging World - Demographics and challenges. *Gynecol Endocrinol*. 2008;24(1):1-3.
- [3] Fuster V. Changing demographics: a new approach to global health care due to the aging population. *J Am Coll Cardiol* 2017;69(24):3002-3005.
- [4] Chávez-Sánchez I, González-Torres P, Tejada-Gutiérrez A, Rey-Galindo J, Aceves-González C. A step towards inclusive design: comfortable maximum height of a bus step for the elderly mexican population. In: Bagnara S, Tartaglia R, Albolino S, Alexander T, Fujita Y, editors. *IEA 2018. Advances in Intelligent Systems and Computing*, vol 824. Cham: Springer; 2019. p. 1634-1641.
- [5] Jamei E, Chan M, Chau HW, Gaisie E, Lättman K. Perceived accessibility and key influencing factors in transportation. *Sustainability*. 2022;14(17):10806.
- [6] Remillard ET, Campbell ML, Koon LM, Rogers WA. Transportation challenges for persons aging with mobility disability: qualitative insights and policy implications. *Disabil Health J*. 2022;15(1):101209.
- [7] Srichuae S, Nitivattananon V, Perera R. Aging society in Bangkok and the factors affecting mobility of elderly in urban public spaces and transportation facilities. *IATSS Res*. 2016;40(1):26-34.
- [8] Uras BHM, Aktan HM. Development of wheelchair-lift prototype for transit buses. 1995;121(2):214–20. *J Transp Eng*. 1995;121(2):214-220.
- [9] Kantawong S. Wheelchair ramp lift boarding supporter for public bus transportation service using RFID and Fuzzy proportional plus integral control system. 2011 International Conference on Information and Electronics Engineering; 2011 May 28-29; Bangkok, Thailand. Singapore: IACSIT Press; 2011. p. 115-119.
- [10] Pourhassana R, Rafieea R, Pourhassana M, Branch I. Design of a novel mechanism for transportation of wheelchair and disabled people into public buses. *Aust J Basic Appl Sci*. 2011;5(5):866-874.
- [11] Mori Y, Sakai N, Katsumura K. Development of a wheelchair with a lifting function. *Adv Mech Eng*. 2012;2012:803014.
- [12] Ansari J. Design and development of a novel wheelchair with lifting and flattening capabilities. 2017 ASEE Annual Conference & Exposition; 2017 Jun 24-28; Columbus, United State. p. 1-12.
- [13] Lythgo N, Begg R, Best R. Stepping responses made by elderly and young female adults to approach and accommodate known surface height changes. *Gait Posture*. 2007;26(1):82-9.
- [14] Sankarlal RL, Duraimurugan P, Karthikeyan G, Seshubabu K. Design and analysis of wheelchair ramp in government buses. *Int J Mech Eng*. 2021;6(3):1535-1538.
- [15] Börklü HR, Bozbuğa F, Sezer HK, Özdemir V. A novel conceptual design of a stairlift for elderly and disabled people. *GU J Sci Part A*. 2018;5(1):17-29.
- [16] Tuan VA, Son DT. Accessibility to public transport systems in developing countries – an empirical study in Ho Chi Minh City, Vietnam. *J East Asia Soc Transp Stud*. 2015;11:1240-1258.
- [17] Loukaitou-sideris A, Wachs M. Transportation for an aging population : promoting mobility and equity for low-income seniors. Report Project 1704. San José: San José State University; 2018.
- [18] Lakhota S, Lassarre S, Rao KR, Tiwari G. Pedestrian accessibility and safety around bus stops in Delhi. *IATSS Res*. 2019;44(1):55-66.
- [19] Aceves-gonzález C, Cook S, May A. Bus use in a developing world city : implications for the health and well-being of older passengers. *J Transp Health*. 2015;2(2):308-316.
- [20] Frost KL, Bertocci G, Smalley C. Ramp-related incidents involving wheeled mobility device users during transit bus boarding/alighting. *Arch Phys Med Rehabil*. 2015;96(5):928-933.
- [21] Jahangir S, Bailey A, Hasan MU, Hossain S, Helbich M, Hyde M. “When I Need to Travel , I Feel Feverish”: everyday experiences of transport inequalities among older adults in Dhaka, Bangladesh. *Gerontologist*. 2022;62(4):493-503.
- [22] Ravi T, Babu Rao G, Praveen Kumar B, Wilson Kumar M, Brieger T. Conceptual design and analysis of smart steps for elderly / differently abled persons in rural public transport buses. *Nano World J*. 2023;9(S4):S192-S198.
- [23] Cripe AR, Caylor WC, inventors. Folding staircase. USA: US Patent US3408959A: 1968.
- [24] Dickhart WW, Marvin RH, inventors. Railway car trap door lift. USA: Patent number 4273498: 1981.
- [25] Hagen H, inventor. Passenger vehicle such as a bus having a laterally extending stair assembly. USA: US Patent US4369984A: 1983.
- [26] Demski RF, Iversen AM, Quinn KJ, Kamprath KV, Willett TC, Roger Lackore J, Friebel DE, Litscher R, inventors. Folding step system for vehicles. USA: US Patent US5584493A: 1996.

- [27] Matre V, inventor. A combined stairs and person hoist. EU: European Patent EP0654006B1: 2000.
- [28] Stefan A. Design of a lifting platform for people with locomotive disabilities to be used on a campus bus design studio/INEGI [thesis]. Portugal: University of Porto; 2009.
- [29] Lee Y, Han S, Ha S. Structural analysis of wheelchair lift system for express buses. *Trans Korean Soc Automot Eng.* 2019;27(1):61-67. (In Korean)
- [30] Rahman MH, Rahman SMM, Bhuiya AT, Sakib S. Design of an accessible door system in high floor buses for wheel chair users. *International Conference on Mechanical, Industrial and Energy Engineering*; 2014 Dec 26-27; Khulna, Bangladesh. p. 1-6.
- [31] Paul YWM, Rao GB, Abraham T. Conceptual design and analysis of easy lift stairs for elderly and physically challenged passengers. *Int J Sci Eng Res.* 2016;7(4):83-88.
- [32] Ahmed AT, Islam SU. Accessible design and fabrication of wheelchair ramp for public bus transportation and design study based on solidworks simulation [dissertation]. Bangladesh: Islamic University of Technology (IUT); 2017.
- [33] Seino A, Kinugawa J, Wakabayashi Y, Itami S, Buranaamon T, Kosuge K. Wheelchair lift which is installable both of steps and stairs. *Trans JSME.* 2019;85(874):1-13. (In Japanese)
- [34] Peravali MS, Rao GB, Bannaravuri PK, Sahu M, Deepak DL, Kandavalli SR, et al. Mechatronic system for an automated dynamics staircase for walking difficulty people to travel in public road transportation vehicles. In: Singh MK, Gautam RK, editors. *Recent Trends in Design, Materials and Manufacturing. Lecture Notes in Mechanical Engineering.* Singapore: Springer; 2022. p. 449-460.
- [35] Kumar S. Tamil Nadu: all new buses purchased must be disabled friendly, rules Madras high court [Internet]. 2021 [cited 2022 Sep 6]. Available from: <https://timesofindia.indiatimes.com/city/chennai/tamil-nadu-all-new-buses-purchased-must-be-disabled-friendly-rules-madras-high-court/articleshow/84008101.cms>.
- [36] Gadkari N. Disabled friendly buses [Internet]. India: Press Information Bureau Government of India Ministry of Road Transport & Highways; 2022 [cited 2022 Sep 6]. Available from: <https://pib.gov.in/Pressreleaseshare.aspx?PRID=1845316>.
- [37] ET Auto. 29% buses made partially accessible for disabled, 5.96% fully accessible: Govt [Internet]. 2022 [cited 2022 Sep 6]. Available from: <https://auto.economictimes.indiatimes.com/news/commercial-vehicle/mhcv/29-buses-made-partially-accessible-for-disabled-5-96-fully-accessible-govt/93009887>.
- [38] Rao S. City gets 26 buses with a lift for differently abled [Internet]. 2020 [cited 2022 Sep 6]. Available from: <https://mumbaimirror.indiatimes.com/mumbai/other/city-gets-26-buses-with-a-lift-for-differently-abled/articleshow/79574934.cms>.
- [39] Kidiyoor S. Buses with wheelchair-lifting facility to be deployed in Bengaluru quickly [Internet]. 2022 [cited 2022 Sep 6]. Available from: <https://www.thehindu.com/news/national/karnataka/buses-with-wheelchair-lifting-facility-to-be-deployed-in-bengaluru-soon/article65521025.ece>.
- [40] Sopam R. Govt set to roll out 20 disabled-friendly buses in Patna [Internet]. 2022 [cited 2022 Sep 6]. Available from: <https://www.hindustantimes.com/cities/patna-news/govt-set-to-roll-out-20-disabled-friendly-buses-in-patna-101650212952118.html>.
- [41] Ramakrishnan S. Disabled activist falls off ramp of 'accessible' bus [Internet]. 2019 [cited 2022 Sep 6]. Available from: <https://www.newindianexpress.com/cities/chennai/2019/Nov/08/disabled-activist-falls-off-ramp-of-accessible-bus-2058657.html>.
- [42] Goswami S. Delhi government to roll out disabled-friendly buses with three doors from March-end [Internet]. 2019 [cited 2022 Sep 6]. Available from: <https://www.hindustantimes.com/delhi-news/delhi-government-to-roll-out-disabled-friendly-buses-with-three-doors-from-march-end/story-ZiVIAy6msLGFVihZkaOyL.html>.
- [43] Sundaram R. Despite TN govt order, disabled are forced to pay on buses [Internet]. 2021 [cited 2022 Sep 6]. Available from: <https://timesofindia.indiatimes.com/city/chennai/despite-tn-govt-order-disabled-are-forced-to-pay-on-buses/articleshow/87638424.cms>.
- [44] Xinder Tech Electronics. Bus wheelchair lift weight capacity, wheelchair elevator for bus and coach [Internet]. [cited 2022 Sep 12]. Available from: https://www.china-wheelchair-lift.com/product/STEP-B-1200-Wheelchair-Lift-semi-automatic_1656.html.
- [45] Xinder Tech Electronics. Wheelchair lifts for disabled people, wheelchair lift hoist [Internet]. [cited 2022 Sep 12]. Available from: https://www.china-wheelchair-lift.com/Product/STEP-A-1200-Wheelchair-lift-fully-automatic_9419.html.