

# The Development Measuring System of Temperature Effect to Produce Electric Power of Solar Cell

Ong-art Sadmai

Department of Electrical Engineering, Faculty of Engineering,  
Rajamangala University of Technology Thanyaburi. Prathumthani Thailand.  
Email: ong-art.s@en.rmutt.ac.th

## ABSTRACT:

This paper focuses on a temperature effects on a PV panel which has been installed in Thailand. The main objective is cleaning PV panels and reduce temperature of PV panel by water injects from waterway and experimental results of PV power what it is difference. This project is designed by PLC control system which water injects and control PV temperature, In addition, this project consists of hardware and software such as water pump, water injection and PLC control has been automatically and it can be control system manually. The automatic control system is working when PV temperature rises up over 45 degree Celsius after that the pumping machine would inject water to the surface of PV panels and it must be stop when the PV panel temperature comes down less than 45 degree Celsius. The result of actual experimental found that the control system has been done correctly under specify condition. The experimental has been shown electrical data before and after water injects on PV system found that the electrical power a bit increases and The energy has been taken from PV panel less than energy consumption equipment of control system which taken to operate the water injecting system.

**Keywords:** Temperature effect, Reduce Temperature of PV cell, Water Feeding

## 1. INTRODUCTION

The Department of Electrical Engineering has been developed green energy by supporting all sustainable energy such as solar energy, wind turbine, fuel cell. The 10kWp Photovoltaic system has been installed more than 4 years ago in the University [1][2]. Thailand is located in tropical Southeast Asia which has average temperature 29.6 degree Celsius [3]. Under standard condition (STD) of PV panel has been tested on 25 degree Celsius, irradiation  $1000\text{W}/\text{m}^2$  found that PV panel can be produced electrical power ( $P_m$ ), open circuit voltage ( $V_m$ ), short circuit current ( $I_{sc}$ ). However, PV panel could work a better under cold weather than hot weather [4] and it is difficult to predict the output dc power due to variations of weather, irradiation and air mass.

This project has been designed and presents temperature controller and cleaning PV cell with microcontroller which reduce temperature of PV panels by spraying water on PV panels. In the last project shows that electrical power of the system can be reduced the electrical power at high temperature. Otherwise, it could be generated high power output. We hardly know that PV system voltage getting low at high temperature and it is smooth every time all day.

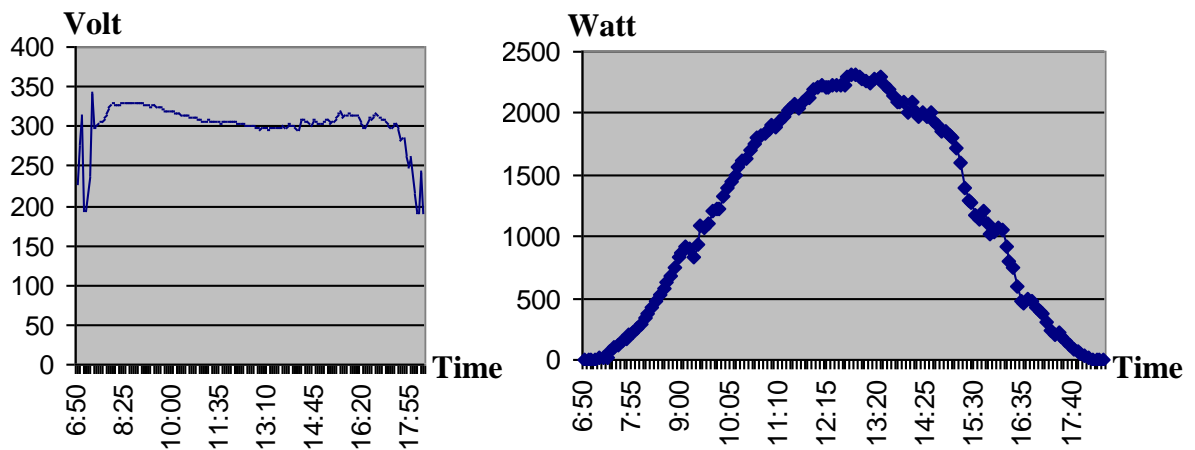

Figure 1: Voltage and Power of the 10 kW system.

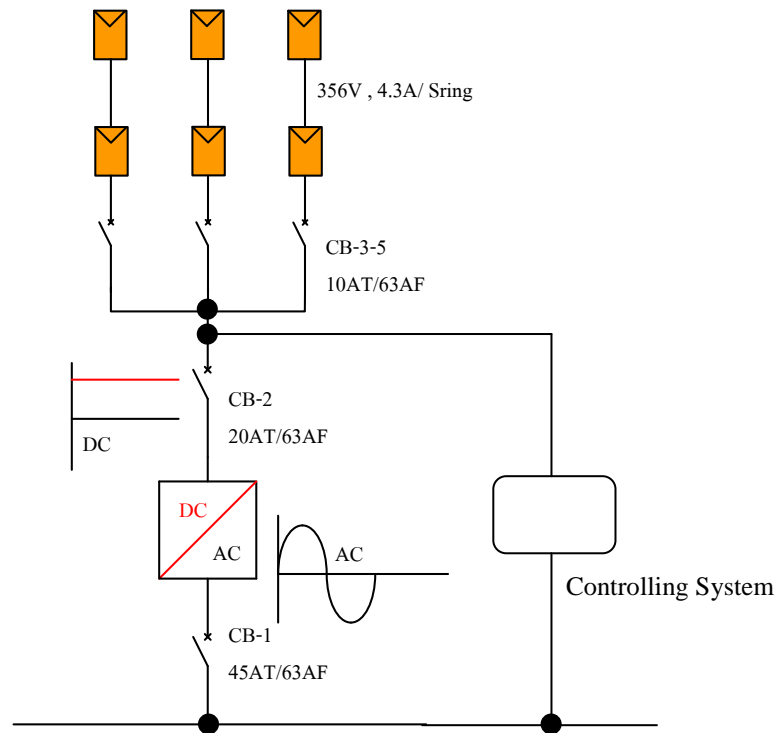

Figure 2: single line diagram of 10 kWp photovoltaic system.

Fig.1 shows DCV (direct current voltage) and AC power of 10kWp Photovoltaic system which has been installed in Thai University. Furthermore, we know that temperature has effectively on PV cell and the system can be produced maximum power output when it works properly at noon and after noon.

Fig.2 shows single line diagram of 10kW photovoltaic system which operate on ten PV panels per string and there are 3 strings per system. This system has been operated more than 4 years ago. After mega flood in Thailand, the system was shutting down more than 9 months.

## 2. TEMPERATURE EFFECT ON PV PANELS AND PV MODEL

Fig.3 shows single diode equivalent PV model which has been studied for electrical power production from sun energy. We well-known about this equivalent circuit which has a current source. There are 3 elements such as diode, shunt resistor and series resistor. The parallel resistor must be high resistance and series resistor is a low resistance. Under this condition for reduce power loss on a series resistor. As can be seen at fig.4 shows VI curve of a PV cell which shows DC voltage of PV cell is varying under different temperature.

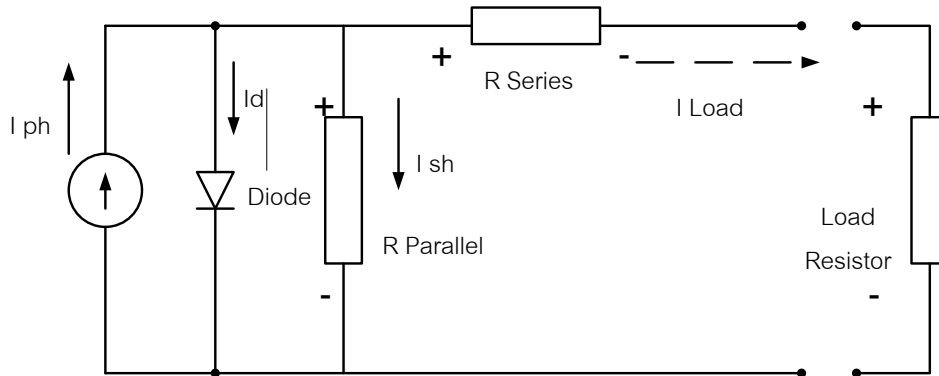

Figure 3: single diode equivalent PV model.

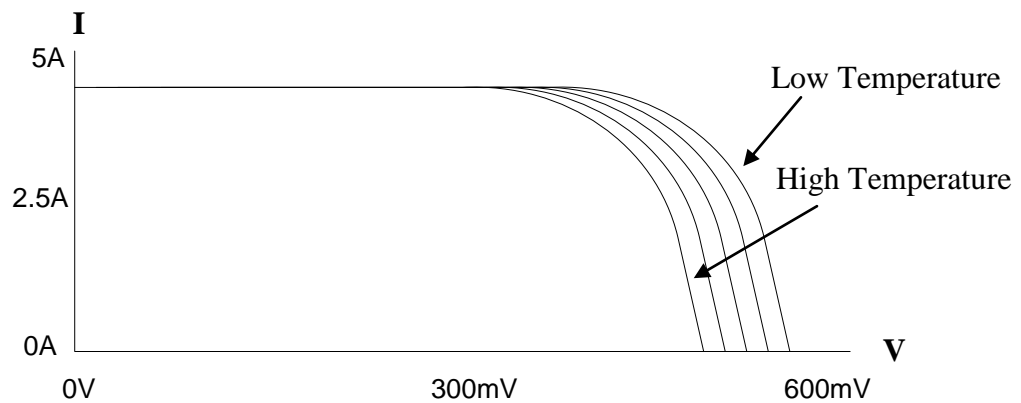

Figure 4: VI curve on several temperatures.

### 2.1 USEFULL EQUATIONS FOR DECISION INTERM OF TEMPERATURE

$$I = I_{ph} - I_D - I_{sh} \quad (1)$$

Where  $I$  and  $I_{sh}$  are load current pass through a parallel resistor and shunt current.  $I_D$  is the diode current,  $I_{ph}$  is photo current of PV cell

$$I = I_{ph} - I_0 \left( e^{\frac{V}{nV_T}} - 1 \right) - \frac{V - IR_S}{R_{sh}} \quad (2)$$

Where  $I_0$  and  $n$  are saturation current and ideal factor.

$$V_T = \frac{kT}{q} \quad (4)$$

Where  $q$  and  $T$  are electron charge and the absolute temperature. However, if we can suppose that  $I_{sc}$  is short circuit and voltage as zero, series resistor is zero. So short circuit current should be equal zero. Also short circuit current and photo current are equal. From equation (5), it shows open circuit voltage.

$$V_{oc} = nV_T \left\{ \left( \ln \left( I_{sc} - \frac{V_{oc}}{I_{sh}} \right) - \ln I_0 \right) \right\} \quad (5)$$

Maximum power of solar cell which can be calculated form equation (6)

$$P_M = V_M \times I_M \quad (6)$$

$$P_M = V_M [I_L - I_0 (e^{\frac{V}{V_T}} - 1)] \quad (7)$$

Where  $\eta$  is an efficiency of solar cell which can be determined from equation (8).  $P_M$  and  $A_{irr}$  are maximum power of PV panel and area is to be absorb sun energy.  $I_{rdiance}$  is irradiation.

$$\eta = \frac{P_M}{A_{irr} \times I_{rdiance}} \times 100\% \quad (8)$$

Where FF is fill factor of multiply between maximum voltage and maximum current has divided by short circuit and open voltage which can be determined from equation (9)

$$FF = \frac{V_M \times I_M}{V_{OC} \times I_{SC}} = \frac{P_M}{P_{OC}} \quad (9)$$

### 3. EXPERIMENTAL SETUP

#### 3.1 CONTROL SYSTEM AND EXPERIMENTAL SETUP

Fig.5 shows control box set for spraying water to PV panels which has been installed under the 10kW Photovoltaic system. There are many equipment of electrical design to control DC motor and AC pumping motor. It can be shown in Table I

**Table I:** specification of components on control system.

	Voltage (V)	Current (A)	Power (W)
PLC	24VDC	400m	7
DC motor	24V	12.50	300
AC motor	220V	2.74	1500

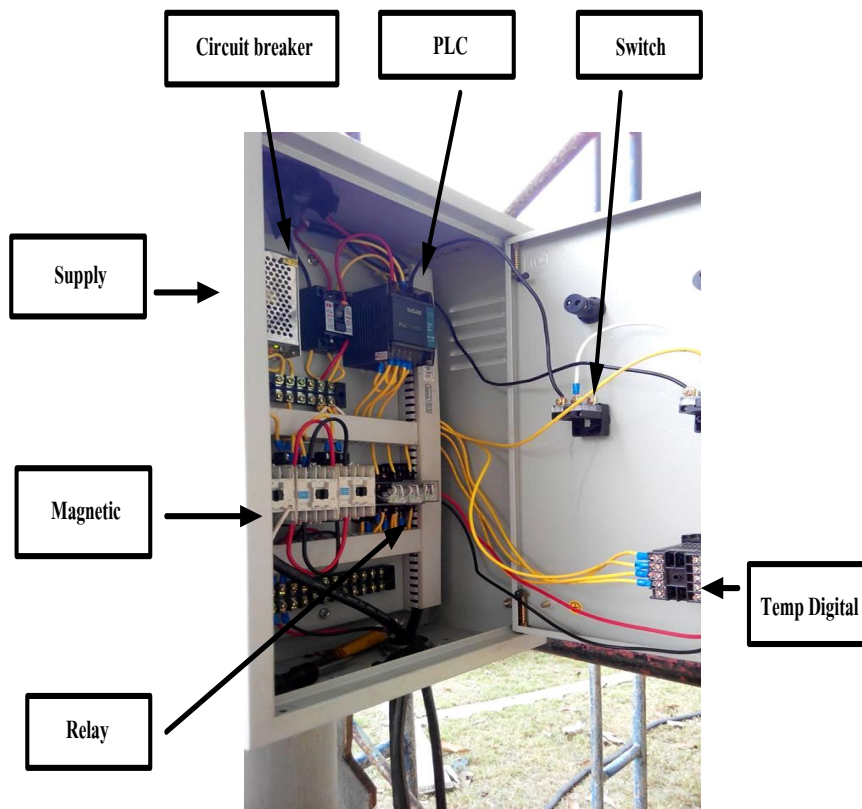

Figure 5: Control system box.

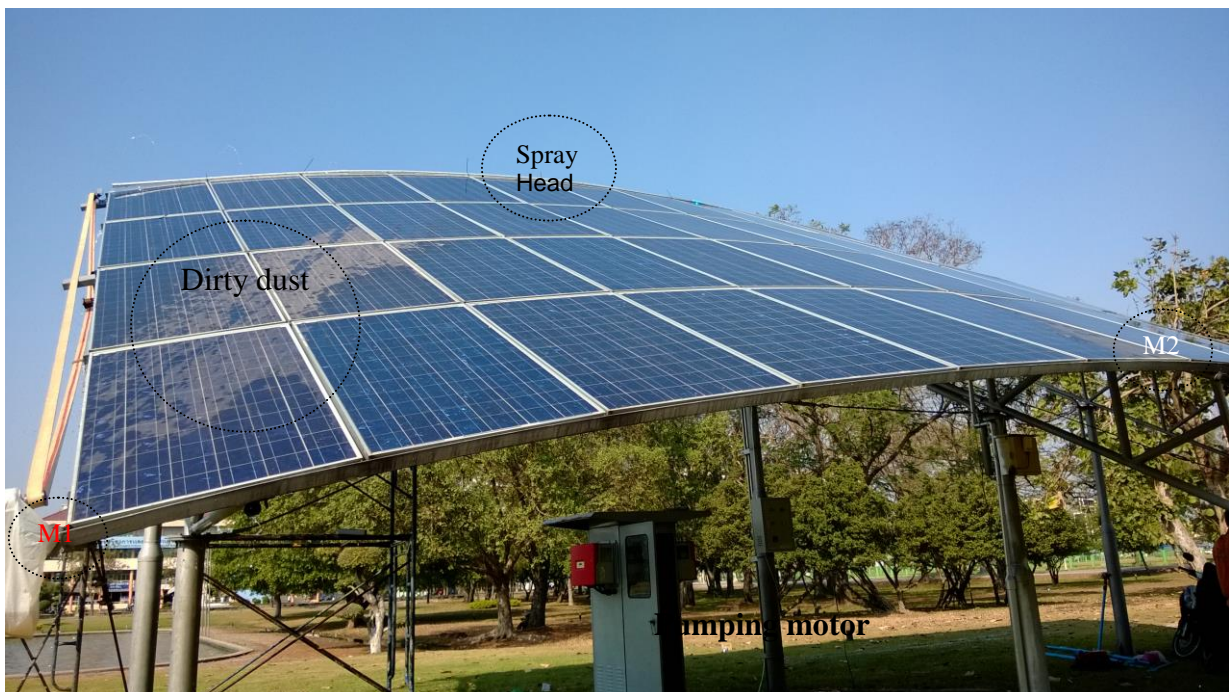

Figure 6: The smallest dirty dust on PV panels.

Fig.6 - 7 shows dust on PV system during control system was spraying water on PV panels. This project uses only inject water. However, it has a long time to cleaning and reduces temperature of PV panels under temperature control at 45 degree Celsius.



Figure 7: Other side of 10kWp photovoltaic system.

### 3.2 EXPERIMENTAL RESULTS

In fig.8 shows electrical power. It can be observed that the electrical power variations from cleaning dust on PV panels and it can be shown before and after spraying water. As expected, after spraying water on PV panels presents an increasing of electrical power from PV system. It is very important if the electrical power output can be generated power output more than before reduce temperature situation.

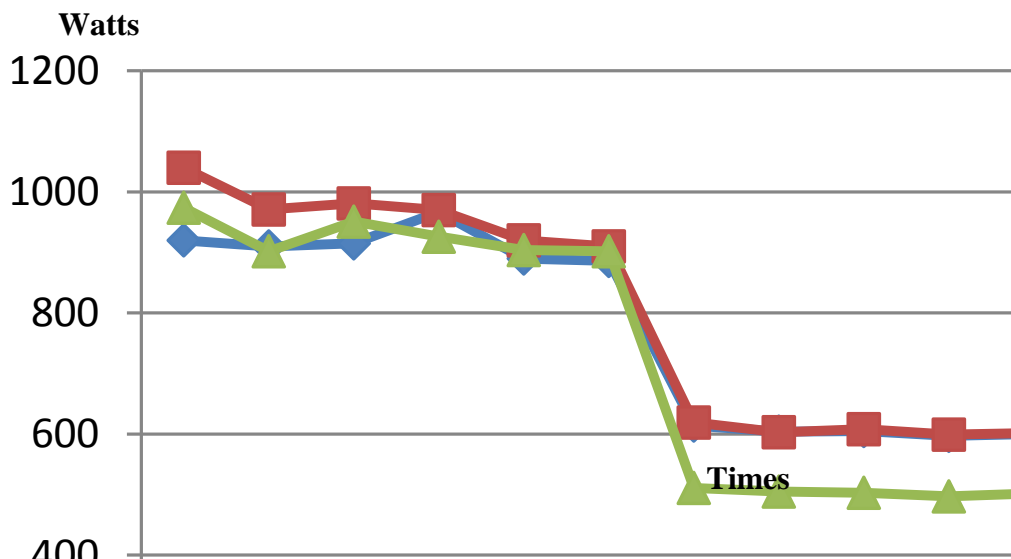

Figure 8: electrical power output between testing control system.

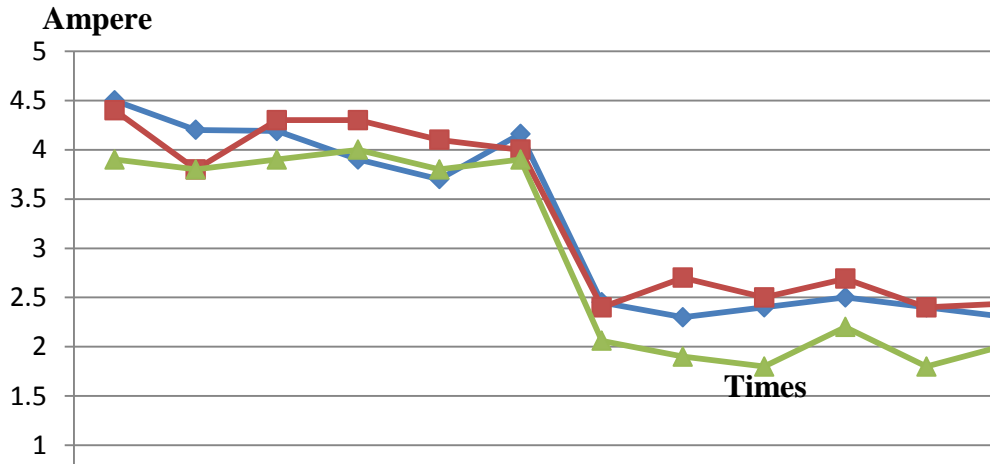

Figure 9: Output current of the single phase inverter.

Fig.9 shows output current of PV system. Actually, this system can be generated current load maximum is 16A.

#### 4. CONCLUSION

The ambient temperature and PV temperature are one of all of major factor that affect the electrical power output. This project wants to study power output of PV system when ambient temperature was change and focuses on a temperature effects on a PV panel which has been installed in Thailand. This project is designed by PLC control system which water injects and control PV temperature, In addition, this project consists of hardware and software such as water pump, water injection and PLC control has been automatically and it can be controlled system manually. The automatic control system is working when PV temperature rises up over 45 degree Celsius after that the pumping machine would inject water to the surface of PV panels and it must be stop when the PV panel temperature comes down less than 45 degree Celsius. The result of actual experimental found that the control system has been done correctly under specify condition. The experimental has been shown electrical data before and after water injects on PV system found that the electrical power a bit increases and energy has been taken from PV panel less than the energy consumption equipment of control system which taken to operate the water injecting system.

#### REFERENCES

- [1] O.Sadmai, S.Hiranvarodom 2010."System Performance Analysis of 10 kWp Photovoltaic System Grid Connected Type Installed at a Thai University" In *Proceeding of renewable energy 2010 conference*. Yokohama , Japan , 27 June – 2 July. Pacifico Yokohama.
- [2] Department of Electrical Engineering, Faculty of Engineering, Rajamangala University of Technology Thanyaburi <http://www.rmutt.ac.th>
- [3] Thai Meteorological Department <http://www.tmd.go.th/info/info.php?FileID=22>
- [4] O.Sadmai, S.Hiranvarodom, B.Plangklang"Case study of Temperature effects to generate electric power from PV array", EENET-1, 19 – 21 November 2008 ,Prathumthni Thailand.
- [5] O.Sadmai, S.Hiranvarodom "Study and Analysis of Solar modules Installed Case study on Lecturer buildings center", EECON31, 29 – 31 October 2551, Thailand
- [6] O.Sadmai "Analysis of 10kW<sub>p</sub> Photovoltaic Grid Connected System at Thanyaburi District", EECON31, 1– 3 December 2010, Thailand